

### THREE RULES TO A WORKING MicroLAN™

#### 1. Control the slew rate of the driver

The MicroLAN consists of three elements, a master, the wiring and connectors and the 1-Wire™ devices. It is an open drain (wired-AND) master / multi-slave network typically using a resistor pull-up to the nominal 5V operating supply at the master. A communication cycle begins when the transistor in the master actively pulls the line to a logic zero, a 1-Wire slave holds the zero if applicable, and the resistor pull-up returns the line to a logic one after both the master and slave release the line. If the transistor pulls the line low in less time than the transition takes to traverse the electrical length of the cable, the MicroLAN is operating in a transmission line environment and reflections from the line end can cause bit errors. Because it is not possible to terminate the MicroLAN cable in its characteristic impedance, when this condition exists the slew rate of the bus transistor must be controlled. A slew rate of 3 to 4 microseconds is recommended for bus lengths exceeding 300 meters or more.

On the rising edge, as the capacitive load on the MicroLAN increases either by adding 1-Wire devices, or cable capacitance by making the line longer, the time to return the line to the supply voltage increases. If the product of the total capacitive load (which includes line, device and stray capacitance), and the pull-up resistor value results in a time constant (RC) that exceeds the bit time slot defined by protocol, communication ceases. For this reason unused wires in a cable should be left unconnected. Grounding them can increase the capacitive load so significantly that the pull-up can not raise the line above the logic switching threshold in the bit time. If the value of the pull-up resistor is already the minimum (1.5K) that generates a recognized zero level, an active pull-up must be substituted. Of course, the same rules apply to an active pull-up as to a pull down, and the slew rate must be controlled when operating in a transmission line environment. This is of little concern with a passive pull-up resistor as the RC time constant has an inherently slow slew rate.

#### 2. Take care in selecting a cable

The performance of the MicroLAN is largely unaffected by the number of 1-Wire devices on the line. It is the cable connecting the master and the 1-Wire devices that largely controls and limits the MicroLAN network. For short runs up to 30 meters, cable selection for use on the MicroLAN is simple as even flat modular phone cable works with small numbers of 1-Wire devices. However, the longer the MicroLAN, the more important cable properties and therefore cable selection becomes. Cables display distinctive properties of resistance, capacitance and inductance, which in turn are determined by cable geometry, and the size and spacing of the conductors and their surrounding dielectric. These physical properties define the characteristic impedance, the signal bandwidth supported and the propagation velocity of the cable. Specifically, cable resistance reduces the zero logic level noise margin, although values to 100 ohms are acceptable. Cable capacitance however, which can range from 30 pF/m to 100 pF/m, loads the MicroLAN driver, increasing not only the pull-up time constant (RC) but also the peak current flowing in the cable as the master transistor turns on and discharges the line. If this transistor turns off before the charge stored in the line capacitance is completely discharged, the residual current left flowing in the line determines the amplitude of the inductive voltage generated. The resulting voltage seen at the driver can become large enough to interfere with communication. At the far end of the cable, this inductively generated voltage swings negative, reverse biasing the substrate of the 1-Wire device closest to the cable end which in turn clamps the voltage at a diode drop.

The inductance of concern is the differential inductance which is that measured across the cable input with the two wires of the line shorted together at the far end. Differential inductance is substantially lower than the inductance of a single wire because the current flows in opposite directions in the pair and in the ideal case would cancel completely. Differential inductance decreases as the distance between conductors is

reduced, so use of adjacent pairs, or preferably, twisted pairs is recommended. Twisted pairs reduce unwanted coupling from nearby interference sources because the currents induced in the wires flow in opposite directions in the two conductors and tend to cancel. Category 5 twisted pair phone line is recommended for all but the most demanding performance requirements. When line length, device number or more than one MicroLAN per cable is required, use IEEE 1394 ("Firewire") compliant cable. Firewire is a doubly shielded cable containing two individually shielded twisted pairs, plus two separate conductors to carry power. Its controlled impedance and low inductance provides excellent MicroLAN performance.

### 3. Keep the bus running

As previously stated, as the inductance in the line increases, the product of  $L di/dt$  can generate voltage excursions that cause bit errors and reverse bias the substrate of at least the first 1-Wire device at the far end of the cable. These voltages are generated by the current still flowing in the data and return lines of the cable when the transistor in the master is turned off before the charge stored in the line capacitance is fully discharged. The obvious and recommended solution is to maintain the pull down transistor in the on state until the current in the line discharges. If it is not possible to stretch the timing, a Schottky diode placed across the bus at the far end is suggested to clamp the inductive generated voltage overshoot. Connect the diode across the cable with the cathode on the data line, and the anode on the return. Only one diode is required for each length of MicroLAN with problem inductance.

## RECOMMENDED CONTROL SLEW RATE PULL-DOWN FOR MicroLAN

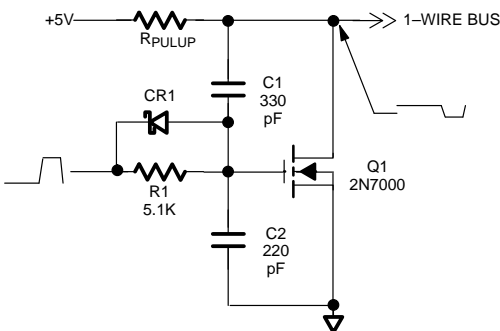

## Its the results that count

By following the rules presented here; using Category 5 twisted pair, controlling slew rates, and substituting an active pull-up, reliable communication over 300m of cable with over 500 various 1-Wire devices has been demonstrated. Without slew rate control and active pull-up, the limit was about 100 meters with 150 1-Wire devices

## CHECK LIST FOR MicroLAN BUS LENGTHS OF 300 METER OR GREATER.

### Select Cable

- Good                               - twisted pair phone
- Better                               - Category 5 twisted pair
- Best                                 - IEEE 1394

### Control Slew Rate

- Limit the slew rate of the pull down to about 3 to 4 microseconds

### Use an active pull-up

- Replace the pull-up resistor with active pull-up circuitry. Limit the slew rate to about 3 to 4 microseconds

### Discharge the line capacitance completely

- Keep the bus master transistor on until the line current dissipates.

## WAVEFORM EXAMPLES

